

# INSTALLATION INSTRUCTIONS AND PARTS LIST

## VEHICLE APPLICATION:

**MODEL 250823 (12" X 23") FRONT OR REAR MUDGUARDS**  
2008 AND NEWER FORD SUPER DUTY SINGLE WHEEL TRUCKS

1. READ INSTRUCTIONS COMPLETELY AND CHECK TO MAKE SURE THAT ALL REQUIRED PARTS (LISTED ON SERVICE PARTS LIST) ARE ON HAND BEFORE STARTING THE INSTALLATION.
2. PREPARE THE SPLASH GUARDS AND VEHICLE FOR SPLASH GUARD INSTALLATION AS FOLLOWS:
  - 2.1. AT THE FRONT: (1) - INSTALL A U-TYPE SPEED NUT (ITEM #7) IN THE TOP HOLE IN THE WHEEL WELL FLANGE. (THREAD ON SPEED NUT MUST BE ON THE BACK SIDE OF THE FLANGE). (2) - REMOVE THE FACTORY WHEEL WELL LINER RETAINER SCREW. (THIS SCREW MAY BE REUSED).

### **MOUNTING 250823 MUDGUARDS ON THE FRONT: (SEE SHEET #2)**

3. INSTALL THE MUDGUARDS AS FOLLOWS:
  - 3.1. POSITION THE MUDGUARD AGAINST THE WHEEL WELL FLANGE SO THAT THE TOP HOLE AND THE THIRD HOLE DOWN IN THE MUDGUARD LINE UP WITH THE HOLES IN THE WHEEL WELL FLANGE. INSTALL A HEX HEAD SEMS SCREW (ITEM #6) IN THE TOP HOLE AND REINSTALL THE FACTORY WHEEL WELL LINER RETAINER SCREW IN THE SECOND HOLE. (LEAVE THESE FASTENERS FINGER TIGHT).
  - 3.2. USING THE INBOARD UPPER HOLE AS A PILOT, DRILL A 1/4" DIA. HOLE THRU THE WHEEL WELL LINER. INSTALL A #10-24 X 1.00" TRUSS HEAD SCREW, #10 FLAT WASHER AND #10-24 SERRATED FLANGE NUT, AND NYLON SPACER AS SHOWN. INSURE THE MUDGUARD IS LEVEL AND TIGHTEN THE FASTENERS.
  - 3.3. MOVE THE MUDGUARDS IN OR OUT AS DESIRED, INSURE THE MUDGUARD IS LEVEL AND TIGHTEN ALL FASTENERS.

### **MOUNTING 250823 MUDGUARDS ON THE REAR: (SEE SHEET #3)**

4. INSTALL THE MUDGUARDS AS FOLLOWS:
  - 4.1. POSITION THE MUDGUARD AGAINST THE WHEEL WELL FLANGE SO THAT THE SECOND HOLE FROM THE TOP LINES UP WITH THE HOLE IN THE WHEEL WELL FLANGE. INSTALL A #10-24 X 1.00" TRUSS HEAD SCREW (ITEM #3), #10 FLAT WASHER (ITEM #5) AND #10-24 SERRATED FLANGE NUT (ITEM #4) AS SHOWN. (LEAVE THESE FASTENERS FINGER TIGHT).
  - 4.2. MOVE THE MUDGUARDS IN OR OUT AS DESIRED, LEVEL THE MUDGUARDS, TIGHTEN THE TOP FASTENERS AND CLAMP THE TOP OF THE MOUNTING BRACKET TO THE INNER WHEEL WELL PINCH WELD.
  - 4.3. USING THE FORTH HOLE DOWN FROM THE TOP AS A PILOT, DRILL A 1/4" DIA. HOLE THRU THE CENTER OF THE WHEEL WELL FLANGE. INSTALL A #10-24 X 1.00" TRUSS HEAD SCREW, #10 FLAT WASHER AND #10-24 SERRATED FLANGE NUT AS SHOWN. INSURE THE MUDGUARD IS LEVEL AND TIGHTEN THE FASTENERS.
  - 4.4. USING THE HOLE IN THE BRACKET (ITEM #7) AS A PILOT, DRILL A 3/16" DIA HOLE THRU THE BOX PINCH WELD AND FASTEN WITH A 1/4" X 3/4" THREAD FORMING SCREW (ITEM #6).
  - 4.5. INSTALL A #10-24 X 1.00" TRUSS HEAD SCREW (ITEM #3, #10 FLAT WASHER (ITEM #5) AND #10-24 SERRATED FLANGE NUT (ITEM #4) AS SHOWN.



(A LIVERNE Company)

1200 E. Birch St.

Brandon, SD 57005

550183 SHEET 1 01JUL08

SERVICE PARTS LIST

2008 FORD SUPER DUTY  
MODEL NO. - 250823

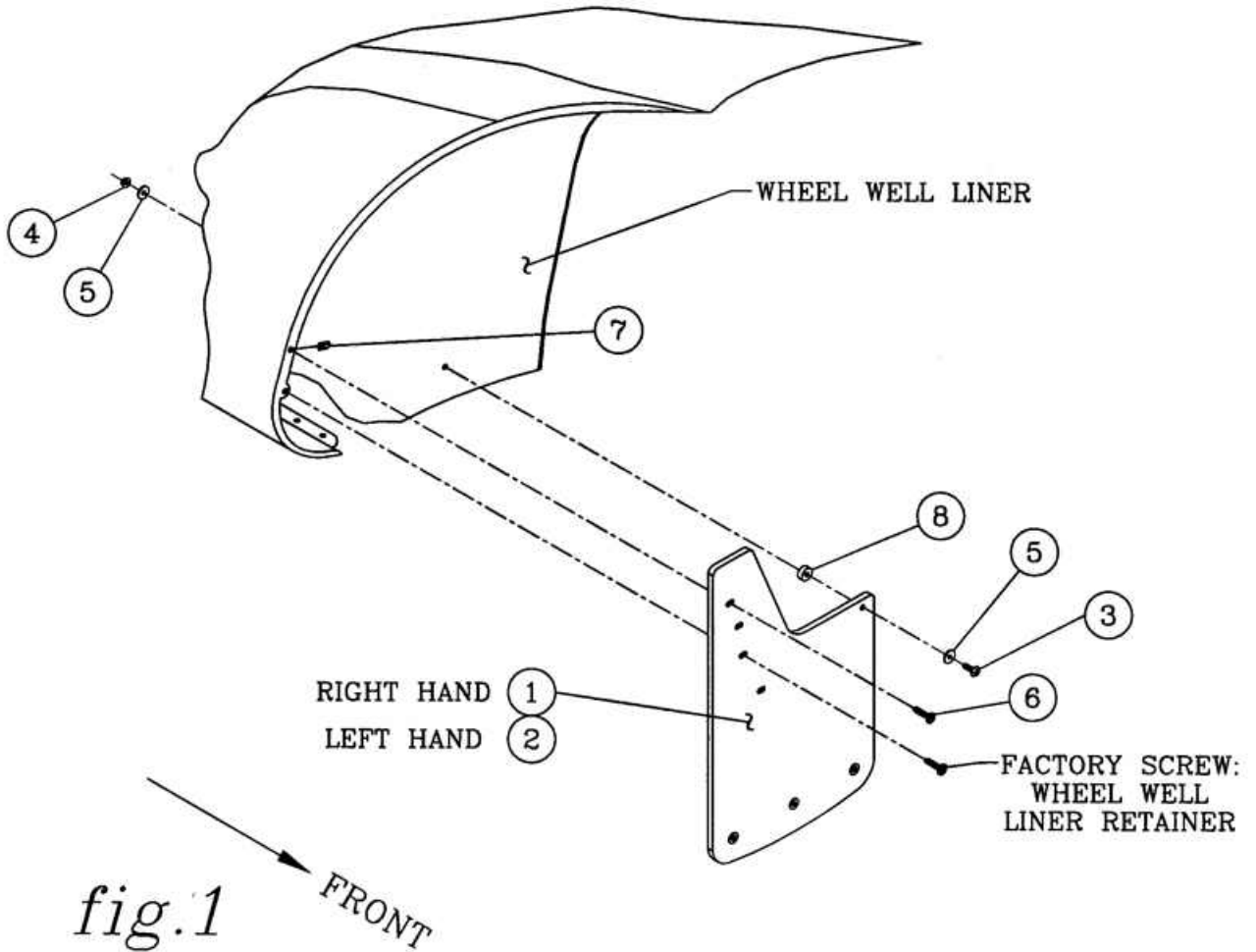

fig.1

FRONT

FRONT INSTALLATION  
RIGHT (PASSENGER) SIDE SHOWN

ITEM	PART NO.	QTY	DESCRIPTION
1	550181	1	MUDGUARD-RUBBER,12 X 23,FORD S.D.,RH
2	550182	1	MUDGUARD-RUBBER,12 X 23,FORD S.D.,LH
3	105516	2	SCR- TRUSS HD, XREC, SST, #10-24 X 1.00"
4	104261	2	NUT- HEX, SERR FLG, SST, #10-24
5	105511	4	WASHER- FLAT, SST, .203 X .625 X .062
6	105514	4	SCREW-SEMS,HEX HD,M4.2-1.41 X 30mm
7	105518	2	NUT-SPEED,U-TYPE,SGL THD,#8,BLK PHOS PLT
8	107182	2	WSHR-SPCR, NYLON,BLACK,.38X1.0X.25

**LIVERNE**  
TRUCK EQUIPMENT

(A LIVERNE Company)

1200 E. Birch St.

Brandon, SD 57005

550183 SHEET 2 01JUL08

SERVICE PARTS LIST

2008 FORD SUPER DUTY  
MODEL NO. - 250823

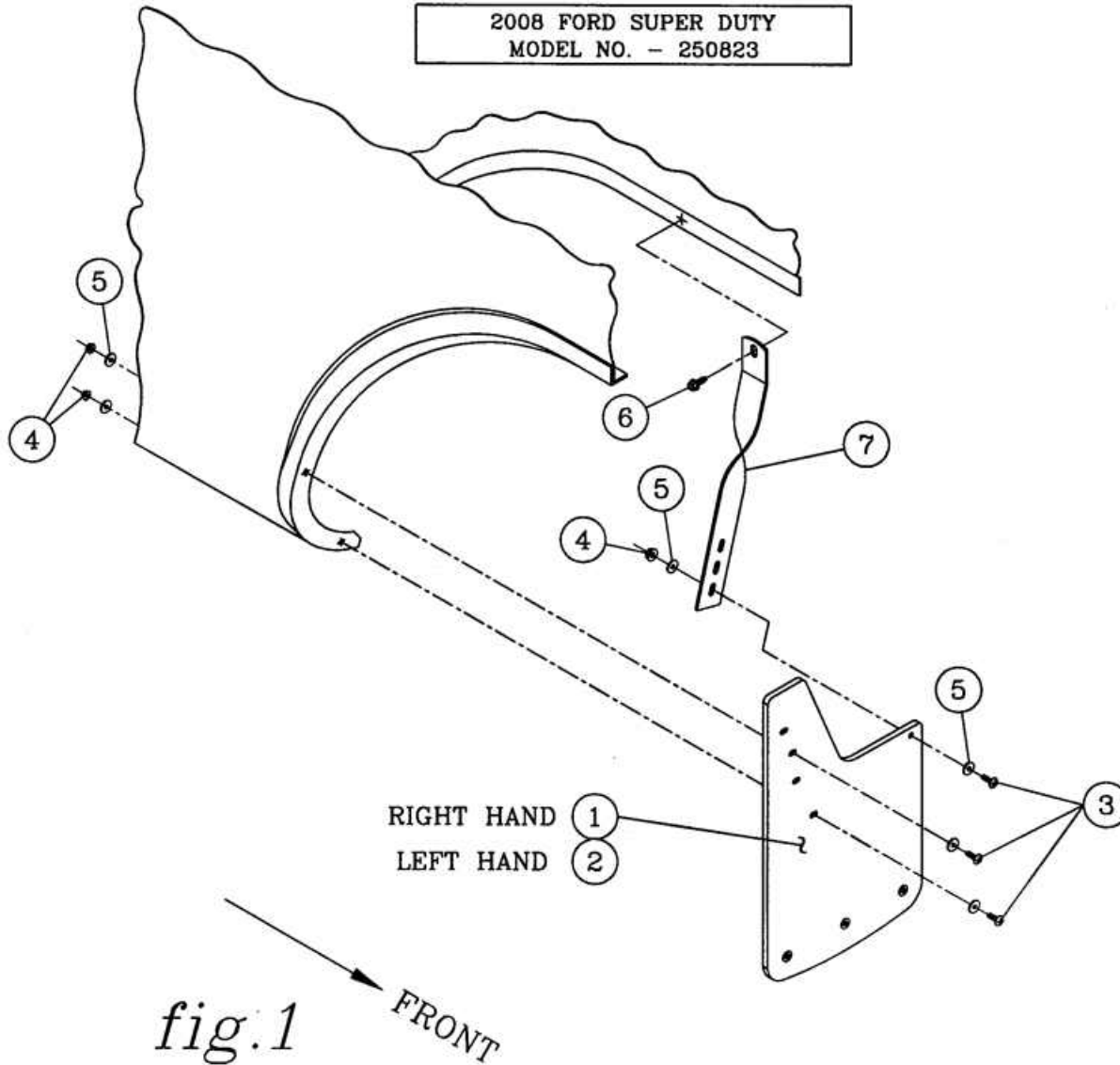

fig.1

RIGHT HAND 1  
LEFT HAND 2

FRONT INSTALLATION  
RIGHT (PASSENGER) SIDE SHOWN

ITEM	PART NO.	QTY	DESCRIPTION
1	550181	1	MUDGUARD-RUBBER,12 X 23,FORD S.D.,RH
2	550182	1	MUDGUARD-RUBBER,12 X 23,FORD S.D.,LH
3	105516	6	SCR- TRUSS HD, XREC, SST, #10-24 X 1.00"
4	104261	6	NUT- HEX, SERR FLG, SST, #10-24
5	105511	12	WASHER- FLAT, SST, .203 X .625 X .062
6	102694	2	SCREW- TF, AB, SST, 1/4 X 3/4
7	544060	2	BRACKET - MOUNTING

**LIVERNE**  
TRUCK EQUIPMENT

(A LIVERNE Company)

1200 E. Birch St.

Brandon, SD 57005

550183 SHEET 3 01JUL08