

INSTALLATION INSTRUCTIONS AND PARTS LIST

APPL: 45/460413 STEEL (BLACK) & STAINLESS STEEL NERF BARS ON:
2004 AND NEWER CHEVY COLORADO, GMC CANYON CREW CABS



1. READ INSTRUCTIONS COMPLETELY AND CHECK TO MAKE SURE THAT ALL REQUIRED PARTS (LISTED ON SERVICE PARTS LIST) ARE ON HAND BEFORE STARTING THE INSTALLATION.
2. NERF BAR TUBE AND MOUNTING BRACKET ASSEMBLIES ARE PRE-ASSEMBLED.
 - 2.1. THE REAR MOUNTING BRACKETS ON THESE ASSEMBLIES ARE ROTATED TO THE FRONT (INBOARD OF LEGS) FOR SHIPPING PURPOSES. THESE BRACKETS MUST BE ROTATED TO THE VERTICAL POSITION AND THE 1/2" BOLTS MUST BE TORQUED TO 65 LB. FT
3. ASSEMBLE THE THREADED STUD & FASTENERS TO THE REAR BRACE AS FOLLOWS,
 - 3.1. INSTALL 3/8" SERRATED FLANGE NUTS (ITEM #8) BACKWARDS, TO THE END OF THE THREAD, ON EACH END OF THE THREADED STUD (ITEM #6).
 - 3.2. ON THE INBOARD SIDE OF THE STUD, INSTALL A 3/8" FLAT WASHER (ITEM #9). THEN PUSH THE 3/4" THICK RUBBER WASHER (ITEM #7) & FLAT WASHER TIGHT UP AGAINST THE SERRATED FLANGE NUT. **(THE END OF THE THREADED STUD SHOULD BE RECESSED AT LEAST 1/8" BACK IN THE HOLE OF THE RUBBER WASHER).** INSTALL THE OUTBOARD END OF THE STUD ASSEMBLY THRU THE HOLE IN THE MOUNTING BRACKET AND INSTALL A 3/8" SERRATED FLANGE NUT. (FINGER TIGHT ONLY).
4. REMOVE THE FOUR (4) APPLICABLE BODY MOUNT BOLT ASSEMBLIES FROM THE VEHICLE.
 - 4.1. ALL OF THESE BOLTS ARE REUSED IN THIS INSTALLATION.
 - 4.2. THE BODY MOUNT STEEL WASHER PLATES WITH RUBBER CUSHIONS ARE ATTACHED TO THE BOLTS AND ARE REUSED. SPACER PLATE MUST BE SLID IN BETWEEN THE RUBBER CUSHION, AND THE NERF BAR MOUNTING BRACKET. (SEE ATTACHED DRAWING).
5. POSITION THE NERF BAR ASSEMBLY UP UNDER THE BODY MOUNTS: (NOTE: LUVERNE DECAL IS ON THE FRONT DRIVER SIDE).
 - 5.1. ON THE FRONT MOUNT, MAKE SURE THAT THE BRACKET IS CENTERED IN THE CIRCULAR OPENING. TIGHTEN BODY MOUNT BOLT.
 - 5.2. REPEAT OPERATION 4.1 FOR THE REAR MOUNT. IF THE BRACKET DOES NOT CENTER, THE REAR BRACKET CAN BE MOVED SLIGHTLY BY LOOSENING THE BOLT THAT ATTACHES THE BRACKET TO THE NERF BAR. RETIGHTEN BOLT TO SPECIFIED TORQUE SPEC.
 - 5.3. TORQUE ALL BODY MOUNTING BOLTS TO 45 LB. FT.
 - 5.4. ADJUST THREADED STUD TO GET PROPER TENSION.

SERVICE PARTS LIST

ITEM	PART NO.	QTY	DESCRIPTION
1	551081	2	NERF BAR WLDMT- LH/RH,SST,460413
1	551083	2	NERF BAR WLDMT- LH/RH,STL,BLACK,450413
2	104249	4	BOLT-HEX HD CAP, SERR FLNG, 1/2 -13 X 2.00, ZP
3	551082	1	BRKT-MTG, NB, LH, REAR COLORADO/CANYON
4	551075	2	BRKT-MTG, NB, LH/RH, FRONT, COLRDO/CNYN
5	103950	4	PAD-STEP, NB, BLK, 20.00 LG
6	104686	2	STUD-DBL ,3/8-16, 4.0
7	102592	2	WSHR-RBR, .354 X 1.00 X .748
8	100181	6	NUT-SERR FLG, 3/8-16, ZP
9	100062	2	WSHR-FL, STL, .438X.083
10	551085	4	PLT-SPCR, .1793 X 2.0 X 2.0, BLK ZP
11	551078	1	BRKT-MTG, NB, RH, REAR COLORADO/CANYON

SERVICE PARTS LIST

MODEL NO.-450413 (BLACK)
-460413 (SST)

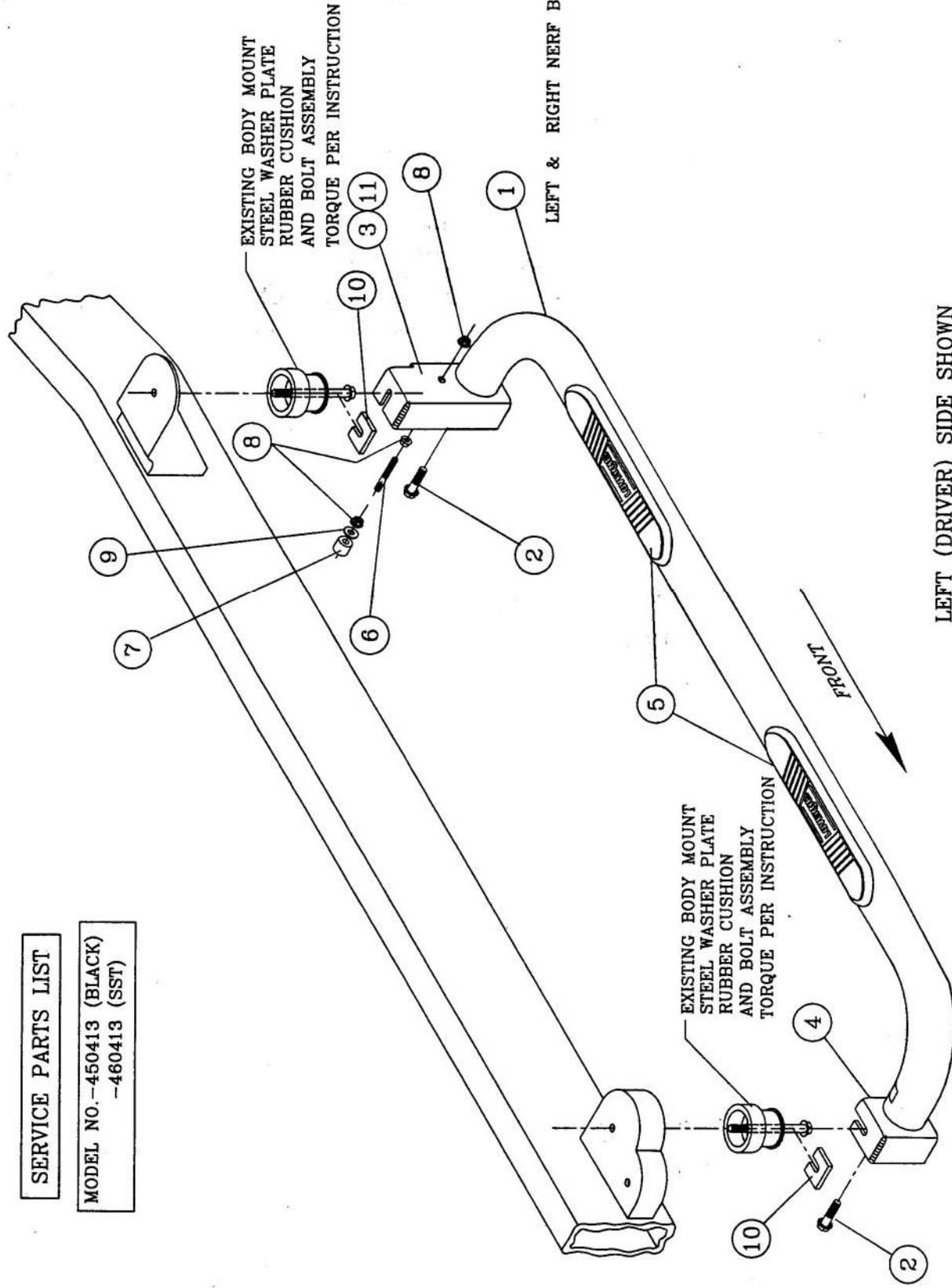

LEFT (DRIVER) SIDE SHOWN
-RIGHT (PASSENGER) SIDE OPPOSITE-

LOVERME
TRUCK
EQUIPMENT
INC.
1200 Birch Street
Brandon, SD 57005

REV D 14JUL05
REV C 14JUL04
REV B 26APR04
REV A 13APR04
551080 SHEET 2 04FEB04