

INSTALLATION INSTRUCTIONS AND PARTS LIST

APPLICATION: 480753 STAINLESS STEEL SIDE ENTRY STEPS:
2007 AND NEWER TOYOTA TUNDRA CREW MAXX CAB



1. Read Instructions completely and check to make sure that all required parts (listed on service parts list) are on hand before starting the installation.
2. The mounting brackets are NOT attached to the step plate for shipping purposes. The *LUVERNE* decal is located on the front driver's side.

Remove the brackets from the carton and attach to both boards using the 10-24x.75 carriage bolts, and 10-24 flange nuts and the small neoprene washers as shown. (item #12, #13, #17). **(NOTE: THE BRACKETS MUST BE PLACE IN THE PROPER POSITION. THEY ARE IDENTIFIED WITH NOTCHES ON THE INBOARD EDGE. [1 NOTCH IS FOR #1 BRACKET, ETC.] #1 WILL BE AT THE FRONT OF THE VEHICLE. SEE FIG. 1).**

3. The step assemblies must be mounted to the inboard surface of the rocker panel per the following instructions.
 - 3.1. Position the step assembly (item #1 thru #13) up under the rocker panel so that the holes in the brackets line up with the holes on the inside of the rocker panel.
 - 3.2. Attach the brackets to the vehicle using M8-1.25 X 25MM screw, lock washer, and flat washer (items #14 #15 #16). Repeat for all brackets.
 - 3.3. Torque all M8 screws to 19 lb. ft.
Torque all 10-24 nuts to 6 lb. in.

SERVICE PARTS LIST

ITEM	PART NO.	QTY	DESCRIPTION
1	551398	1	STEP PLATE-SES,RH,TOY TUNDRA CREW CAB
2	551399	1	STEP PLATE-SES,LH,TOY TUNDRA CREW CAB
3	551362	2	BRKT-MTG, #1, TOY TUNDRA
4	551363	2	BRKT-MTG, #2, TOY TUNDRA
5	551364	2	BRKT-MTG, #3, TOY TUNDRA
6	551365	2	BRKT-MTG, #4, TOY TUNDRA
7	104250	2	END CAP-RH FRONT/LH REAR
8	104251	2	END CAP-LH FRONT/RH REAR
9	102600	4	PAD,STEP PLATE,20.00"
10	102502	2	TRIM-SEAL,SES,EXTRUDED, 95.0"
11	104257	12	NUT-HEX,SGL SELF THD,CAP WASHER,1/4"
12	104258	16	BOLT-CARRIAGE,SST,#10-24 X 3/4"LG
13	104261	16	NUT-SERRATED FLANGE,HEX,SST,#10-24
14	102549	16	SCREW-HEX HD,M8-1.25 X 25MM
15	100030	16	WASHER-LOCK, 5/16"
16	100034	16	WASHER-FLAT, 5/16"
17	104530	16	WASHER-NEOPRENE, .200 X .468 X .03

SERVICE PARTS LIST

MODEL NO. - 480753

DECALS MUST BE AT FRONT ON DRIVERS SIDE

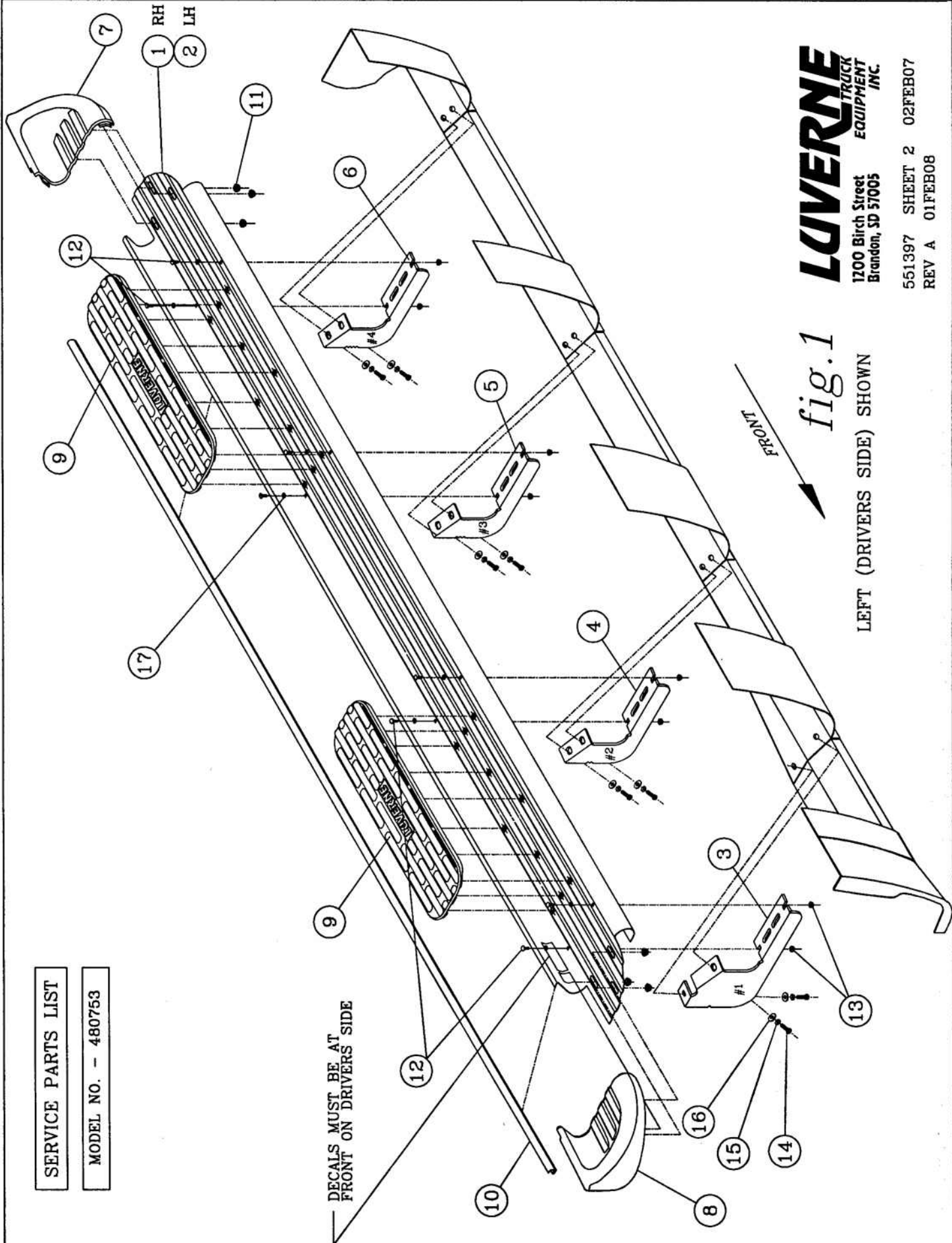

fig.1
LEFT (DRIVERS SIDE) SHOWN
FRONT

LIVERNE TRUCK EQUIPMENT INC.
1200 Birch Street
Brandon, SD 57005

551397 SHEET 2 02FEB07
REV A 01FEB08